

OCULUS | HMC-Anomaloskop

Professional Assessment of Color Vision

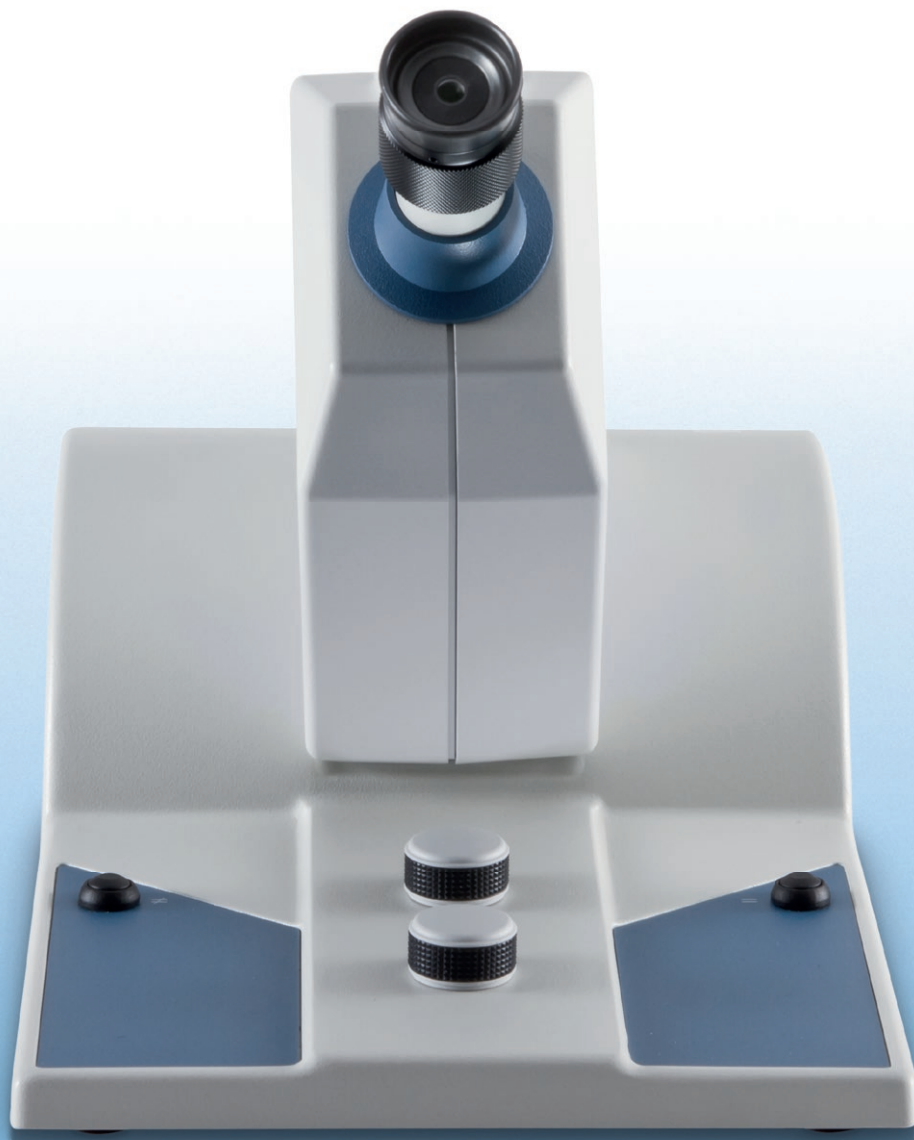

OCULUS HMC-Anomaloskop

The Heidelberger Multi-Color-Anomaloskop is a microprocessor-controlled device for assessment of red-green and blue-green color vision and precision diagnosis of its deficiencies.

There are two versions available, both equipped with integrated automatic neutral adaptation:

- The **HMC-Anomaloskop R** for precision diagnosis of red-green color vision deficiencies (Rayleigh equation). The device was developed in collaboration with Professor Hermann Krastel, Germany.
- The **HMC-Anomaloskop MR** for precision diagnosis of both red-green (Rayleigh equation) and blue-green (Moreland equation) color vision deficiencies. The incorporation of the blue-green range in this device was assisted by Professor J. D. Moreland, Great Britain.

Both HMC-Anomaloskop models can be operated with a computer, laptop or netbook.

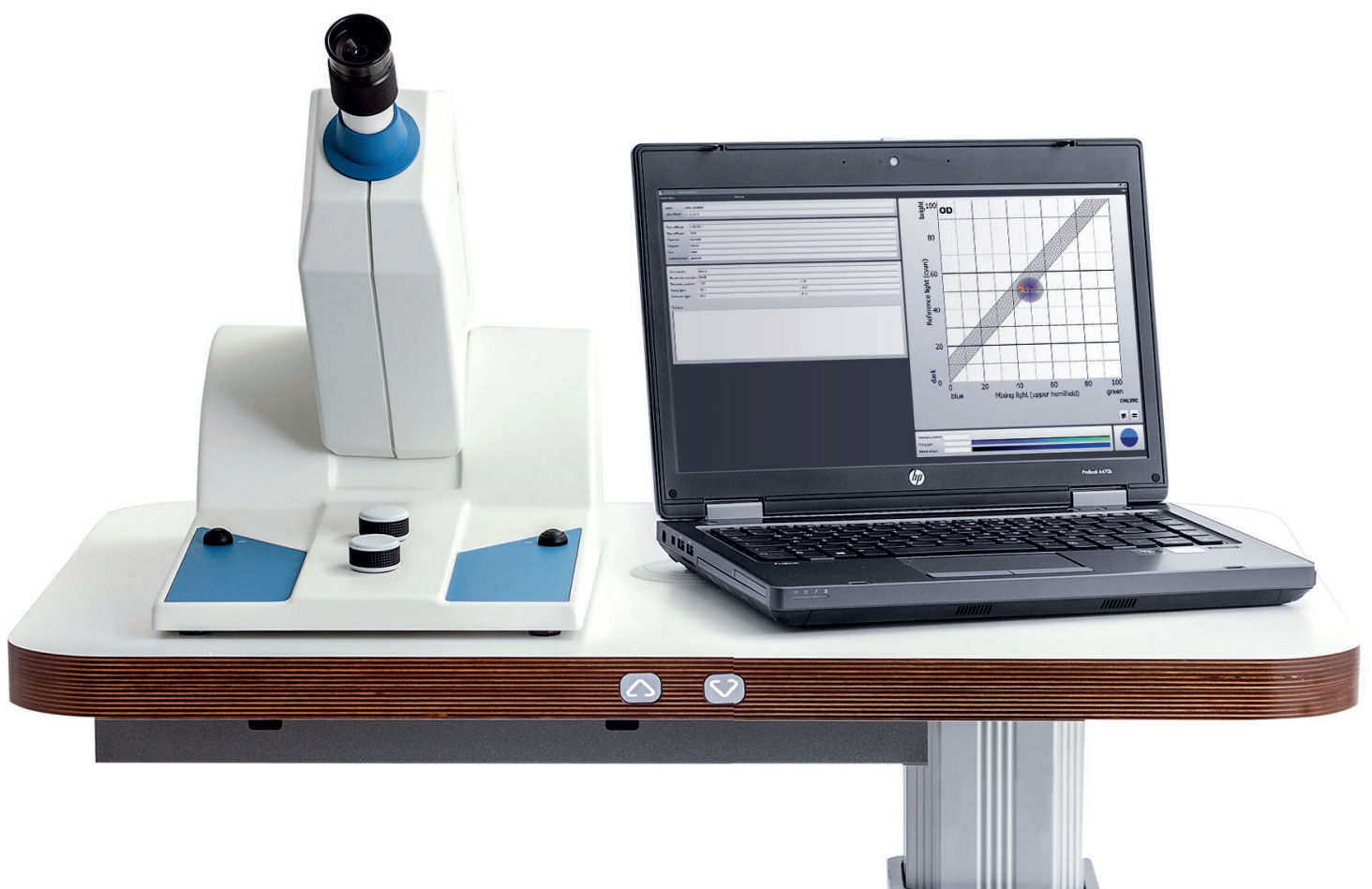

All Features at a Glance

HMC-Anomaloskop for assessment of color vision

- Red-green with the Rayleigh equation
- Blue-green with the Moreland equation
- Suitable for color vision tests in compliance with driving license regulations
- Adjustable automatic neutral adaptation (comparable to a standard "C" light source) during observation of the test field
- Observation of the test field with a standard angle of 2°
- 4° add-on optics for Moreland equation (optional)



- Technical principle: color adaptation based on additive mixing of colors
- Ergonomic design: inclinable tube for optimal, fatigue-free viewing
- Control knobs arranged analogously to the test field for ease of use
- Automatic determination of the anomaly quotient (AQ)

Ergonomic and patient-friendly

High-quality technology and electronics from OCULUS incorporated in an elegantly styled design make the HMC-Anomaloskop an exceptional product/instrument in every respect. Special consideration was given in its development to ergonomic design for both the patient and the examiner.

> *Inclinable tube for a fatigue-free viewing*



The HMC-Anomaloskop software module

The HMC-Anomaloskop comes with a comprehensive Windows® compatible software package and a serial interface cable for communication with a computer, laptop or netbook. This enables you to store, incorporate and compare patient data and examination results. This software can also be integrated into conventional software modules in your practice. The examination procedure can be followed on the graphics display. The anomaly quotient is determined automatically.

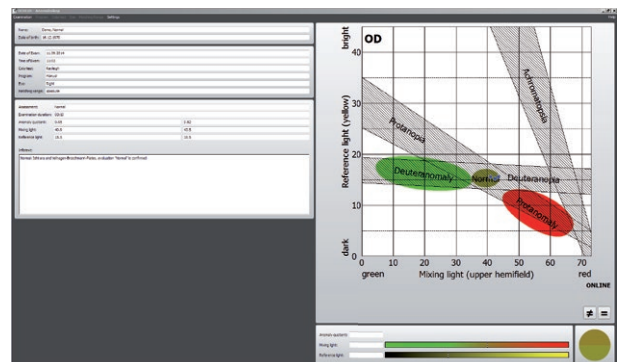

> *Clear-cut, effective examination strategies with the "Pitt diagram"*

Technical Data

OCULUS HMC-Anomaloskop

Color vision tests	
HMC-Anomaloskop (MR)	Red-green color vision test acc. to Rayleigh Blue-green color vision test acc. to Moreland
HMC-Anomaloskop (R)	Red-green color vision test acc. to Rayleigh
Technical specifications	
Neutral adaptation	White light, comparable to a standard "C" light source (6750 K)
Test field	Viewing angle 2°, horizontally split, created by two Ulbricht spheres for high homogeneity
Diopter compensation	± 6 D
Angle of view	35° to 55° (adjustable)
Interface	RS 232 / V24, Sub D-jack, 9-pole
Dimensions (WxDxH) with 4° add-on optics	245 x 390 x 405 mm (9.6 x 15.4 x 16.0 in) 245 x 415 x 435 mm (9.6 x 16.4 x 17.2 in)
Weight	5.4 kg (11.9 lbs) without accessories
Max. power consumption	15 W
Voltage	115 V AC / 230 V AC
Frequency	50 - 60 Hz
Recommended computer specifications	2 GB RAM, 320 GB HDD, 1.8 GHz, Windows® 8, 64bit

CE in accordance with Medical Device Directive 93/42/EEC

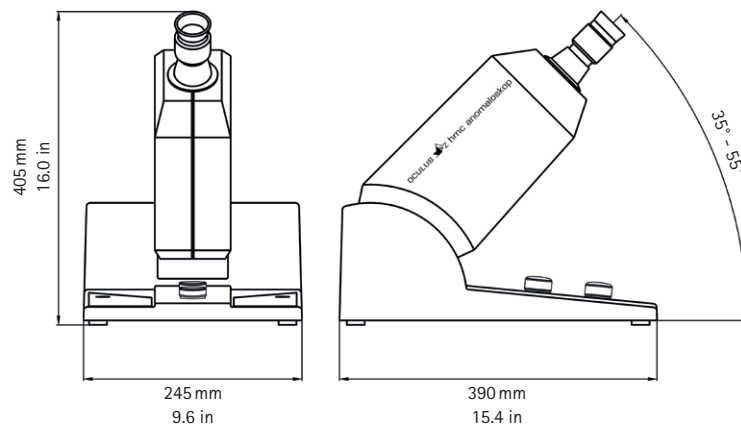

WWW.OCULUS.DE

OCULUS Optikgeräte GmbH
Postfach • 35549 Wetzlar • GERMANY
Tel. +49-641-2005-0 • Fax +49-641-2005-295
Email: export@oculus.de • www.oculus.de

- OCULUS USA, sales@oculususa.com
- OCULUS Asia, info@oculus.hk
- OCULUS Czechia, oculus@oculus.cz
- OCULUS Iberia, info@oculus.es
- OCULUS Poland, biuro@oculus.pl



OCULUS is certified by TÜV according to
DIN EN ISO 13485

